

DEVELON

Material Handler

DX160WMH-7



The DX160WMH-7 is the entry point to Develon's material handler range, combining compact design with powerful performance. Belonging to the 16–20-ton class, it is the perfect solution for facilities where space is limited but efficiency cannot be compromised. Its agile handling makes it especially suited for recycling centers, smaller scrap yards, and waste sorting operations, where precision and maneuverability are key. Operators benefit from a hydraulically elevated cab that provides a commanding view of the work area, enhancing safety and productivity in tight environments. Supported by a robust undercarriage and responsive hydraulic system, the DX160WMH-7 delivers smooth operation and reliable lifting capacity, ensuring consistent performance shift after shift.

Engine

Make	Deutz
Model	TCD 4.1 L4 EU Stage V
Number of cylinders	4
Rated power at 1 800 rpm	105 kW (140 HP)
Displacement	4038 cm ³
Bore and stroke	101 mm x 126 mm
Starter	24 V / 4 kW
Batteries – Alternator	2 x 12 V / 100 Ah
Air filter	Dry air filter

Undercarriage

Tire dimensions	10.00-20 16 PR
Overall width	2540 mm
Wheel base	2600 mm
Tread width	-
Tractive force (breaks)	76.0 kN

Hydraulic System

Maximum system pressure	320 bar
Maximum oil flow	171 l/min

Fluid Capacities

Fuel tank	240 litres
Cooling system	38 litres
AdBlue (DEF) tank	20 litres
Hydraulic oil tank	157 litres
Engine oil	10 litres

CAB

A-weighted emission sound pressure level at the operator's position, LpAd (ISO 6396:2008)	70 dB(A)
A-weighted sound power level, LwAd (2000/14/EC)	95 dB(A)

Swing Mechanism

Maximum swing speed	9/min
Maximum swing torque	34.7 kNm

Drive

Travel speed (creep/low/high)	1 / 5 / 20 km/h
Gradeability	60%
Maximum traction force	76.0 kN

Dimensions

DX160WMH-7

	Unit	Straight Arm
Operating weight	kg	15 000 - 16 500
Boom length	mm	4800
Arm length	mm	3550
A Shipping length	mm	7850
B Tail swing radius	mm	1980
C Shipping height	mm	3230
D Wheel base	mm	2600
E Upper housing width	mm	2500
H Shipping width	mm	2540
I Height over cab	mm	3125

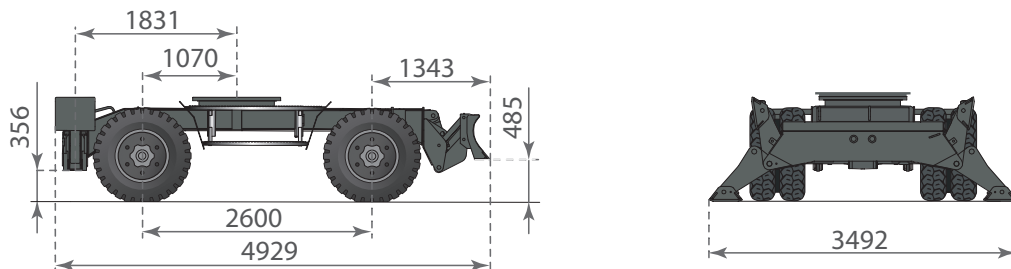
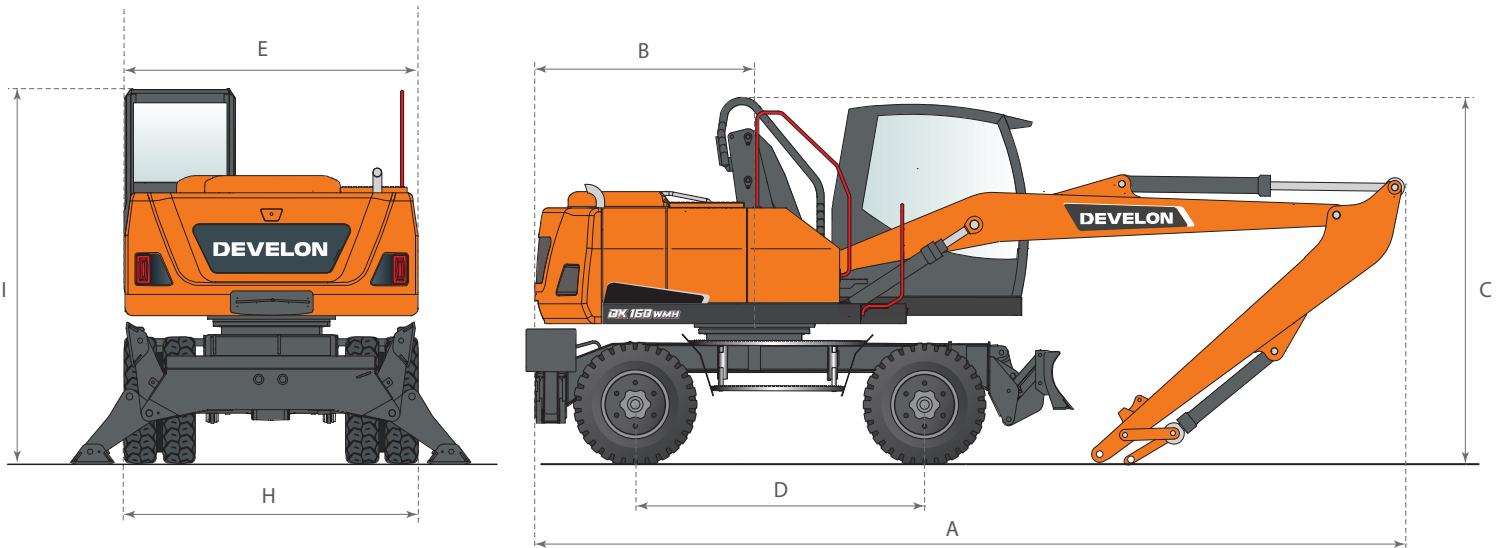

Working Range

DX160WMH-7

	Unit	Straight Arm
Boom length	mm	4800
Arm length	mm	3550
A Max Bucket pin height	mm	9215
B Max working reach	mm	8610
C Max working depth	mm	3960
E Elevating height	mm	3610
I Height over cab	mm	5470

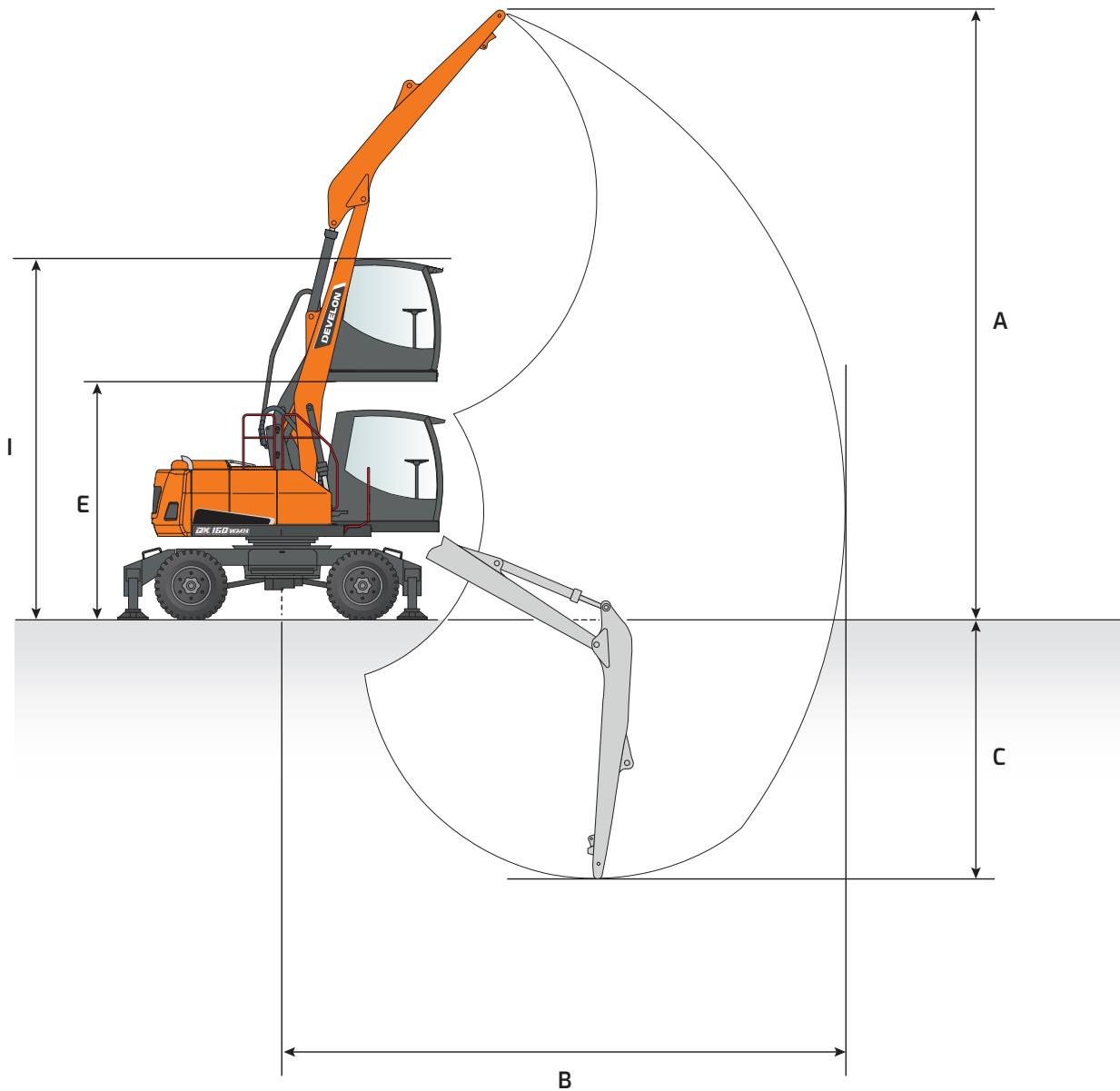

Standard & Optional Equipment

■ Standard ● Optional

Engine

Deutz TCD41 - Common rail 4 cylinder engine (4040 cc) with direct fuel injection and electronic control, water cooled, turbo charged with air-to-air intercooler, cyclone air filter	■
Stage V without EGR, selective catalyst reduction (SCR), diesel oxidation catalyst (DOC) and DPF	■
Reversing fan	■

Hydraulic System

Load sensing hydraulic system	■
Power shift transmission	■
Maximum system pressure : work/travel 320 bar	■
Operating Modes Selection	■
Flow and pressure adjustment of hydraulics lines controlled from the cab	■
Boom & arm cylinder safety valves	■
Mineral hydraulic oil	■
Safety valves (boom & arm)	■
PE3C - 2 way aux. Hydr. line for opening / closing tool (pedal ctrl)	●
PERO - low flow aux. hydr. line for rotating or tilting tool (joystick ctrl)	●

Undercarriage

Heavy-duty material handling frame	■
Heavy-duty axles (2.54m width)	■
Front axle oscillating hydraulically ($\pm 8^\circ$)	■
Front dozer and rear outriggers	■
10.00-20 SOLID tires	●

Safety

Rear and side camera	■
Side mirrors	■
Guard rail	■
Overload warning device	■
Light Pack : 6x LED Lights - 2 on Boom 4 on top of the Cab + rotation beacon.	■
FOGS windscreen and roof	●
Fire extinguisher	●

Cab and Interior

2.3m Elevating Cab with emergency lowering valves	■
7 inch color LCD gauge panel	■
High performance air conditioning with electronic climate control of the temperature	■
RADIO+MP3(STEREO) with Bluetooth Streaming and Hands-free Call	■
USB port	■
Sliding proportional control on joystick of auxiliary hydraulic lines	■
Cab pack : sun visor, roof window and rain shield	■
Fully adjustable air suspension seat with heater	■
Parallel Wipers	■

Other

4,8 m Material handling straight (mono) boom	■
3,5 m Material handling straight arm	■
Double tyres with spacer rings 10.00-20	■
Fuel filling pump	■
Counterweight 3.4 tons	■
1 year warranty / 2.000 hours (whatever occurs first)	■
Telematics system Track unit (hardware installation only, data plan purchase needed)	●
Bucket cylinder (straight arms w/o bucket cylinder in standard)	●
Automatic centralized greasing	●

Certain specification(s) are based on engineering calculations and are not actual measurements. Specification(s) are provided for comparison purposes only and are subject to change without notice. Specification(s) for your individual DEVELON equipment will vary based on normal variations in design, manufacturing, operating conditions, and other factors. Pictures of DEVELON units may show other than standard equipment.

Powered by Innovation

**DISCOVER MORE:
DX160WMH-7**

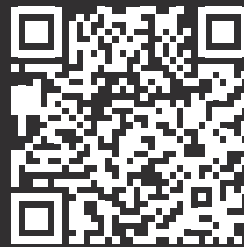

HD Construction Equipment Develon Europe s.r.o.
IBC - Pobrezni 620/3,
18600 Praha 8 - Karlin, Czechia

DEVELON

©2025 HD Construction Equipment Develon Europe s.r.o.
All rights reserved.
SPWMH00001 (08/2025)