

DEVELON

Material Handler

DX350WMH-7



At the top of the range, the DX350WMH-7 represents Develon's ultimate solution for the heaviest and most demanding material handling tasks. Operating in the 35-ton class, it delivers unmatched lifting capacity, reach, and stability, making it the machine of choice for large-scale scrap operations, ports and high-volume recycling facilities. Its reinforced structure and robust hydraulics are designed to handle oversized and dense materials, while the elevated cab ensures maximum visibility and operator confidence. Despite its size and power, the DX350WMH-7 incorporates advanced, energy-efficient technology to keep operating costs under control. Engineered for durability and productivity, this flagship model is built to excel in environments where strength, efficiency, and continuous performance are non-negotiable.

Engine

Make	Deutz
Model	TCD 6.1 L6 EU Stage V
Number of cylinders	6
Rated power at 1 800 rpm	180 kW (245 HP)
Displacement	6100 cm ³
Bore and stroke	101 mm x 126 mm
Starter	24 V / 5.5 kW
Batteries – Alternator	2 x 12 V / 100 Ah
Air filter	Dry air filter

Undercarriage

Tire dimensions	12.00-20 PR
Overall width	3000 mm
Wheel base	3200 mm
Tread width	2320 mm
Tractive force (breaks)	110 kN

Hydraulic System

Maximum system pressure	320 bar
Maximum oil flow	630 l/min

Fluid Capacities

Fuel tank	425 litres
Cooling system	48 litres
AdBlue (DEF) tank	32 litres
Hydraulic oil tank	505 litres
Engine oil	15 litres

CAB

A-weighted emission sound pressure level at the operator's position, LpAd (ISO 6396:2008)	73 dB(A)
A-weighted sound power level, LwAd (2000/14/EC)	104 dB(A)

Swing Mechanism

Maximum swing speed	8.5/min
Maximum swing torque	103.38 kNm

Drive

Travel speed (creep/low/high)	1 / 5 / 16 km/h
Gradeability	33%
Maximum traction force	110 kN

Dimensions

DX350WMH-7

	Unit	Goosneck Arm
Operating weight	kg	33 300 - 38 000
Boom length	mm	8700
Arm length	mm	6900
A Shipping length	mm	12 455
B Tail swing radius	mm	3300
C Shipping height	mm	3400
D Wheel base	mm	3200
E Upper housing width	mm	2740
H Shipping width	mm	3000
I Height over cab	mm	3347

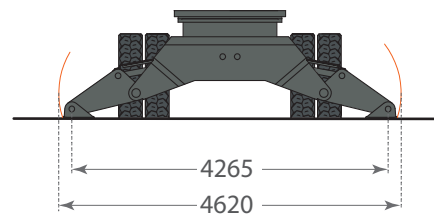
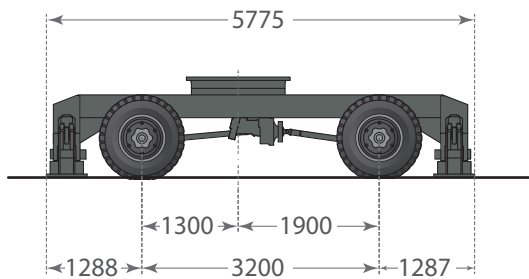
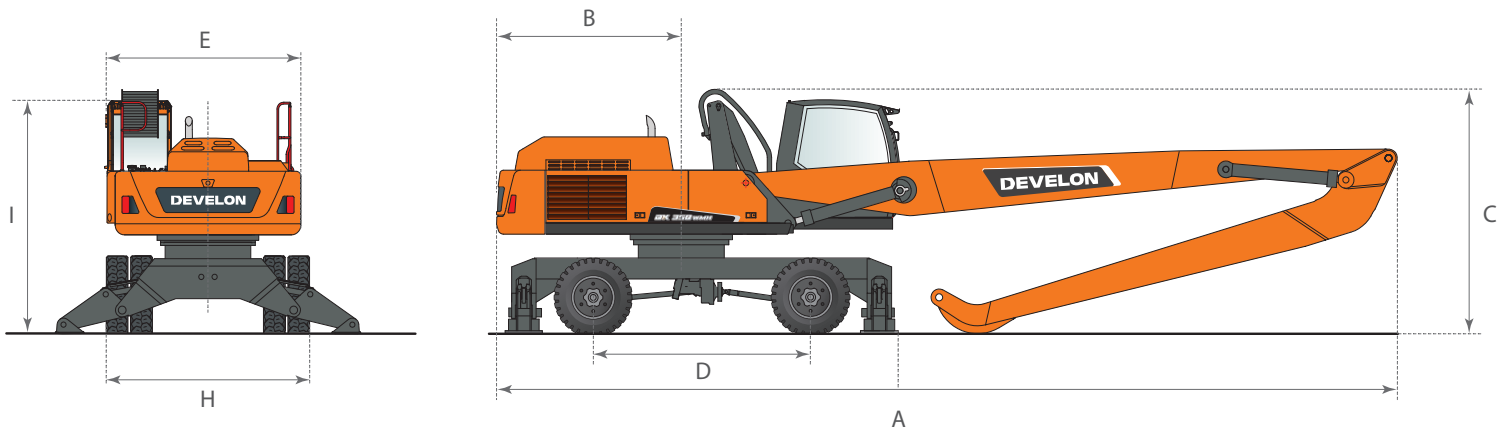

Working Range

DX350WMH-7

		Unit	Goosneck Arm
A	Max Bucket pin height	mm	15100
B	Max working reach	mm	14630
C	Max working depth	mm	4550
E	Elevating height	mm	4228
I	Height over cab	mm	6046

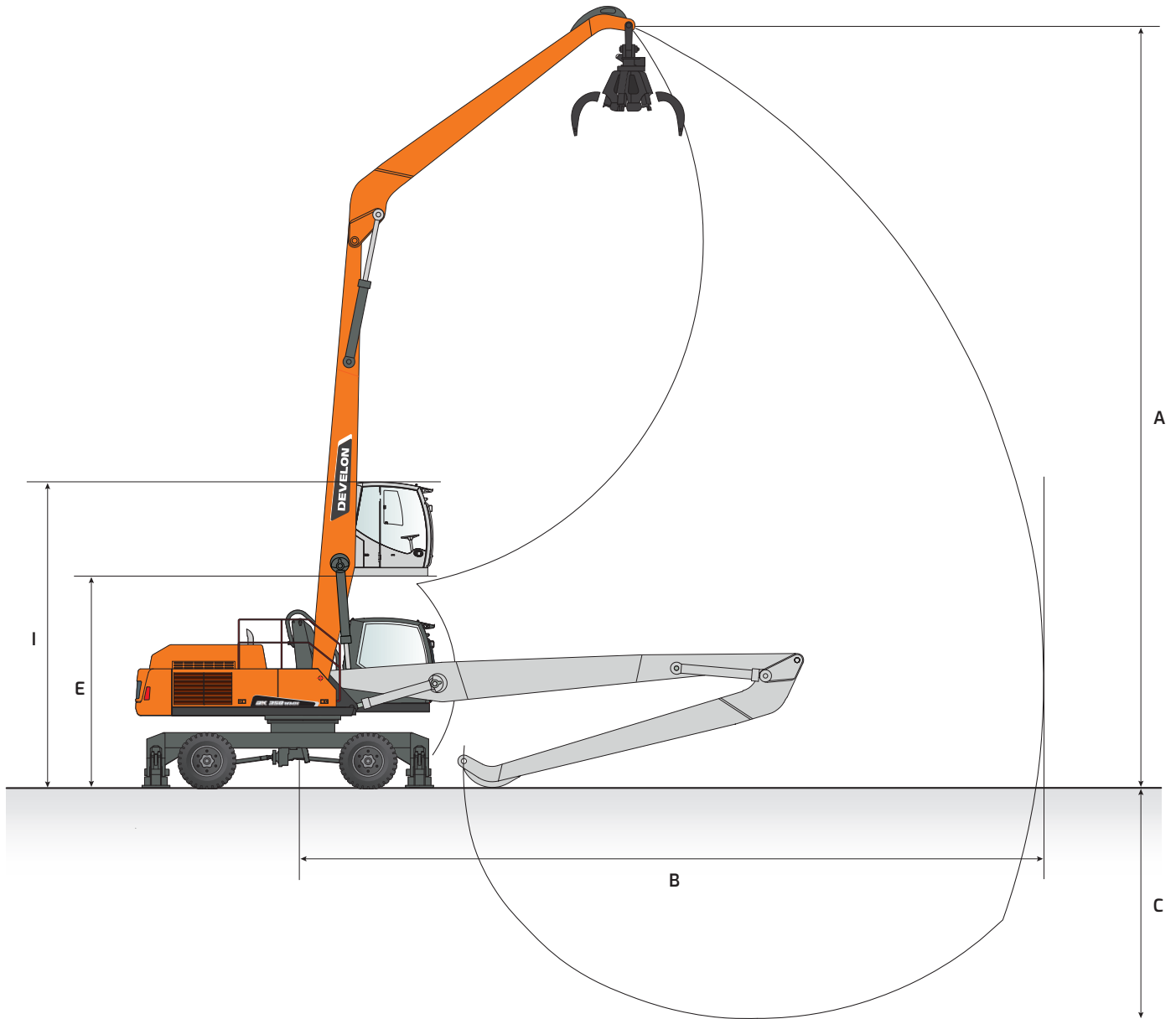

Standard & Optional Equipment

■ Standard ● Optional

Engine

Deutz TCD6.1 - Common rail 6 cylinder engine (6100 cc) with direct fuel injection and electronic control, water cooled. Turbo charged with air-to-air intercooler, cyclone air filter	■
Stage V without EGR, selective catalyst reduction (SCR), Diesel oxidation catalyst (DOC) and DPF	■
Reversing fan	■

Hydraulic System

Load sensing hydraulic system	■
Power shift transmission	■
Maximum system pressure : work/travel 320 bar	■
Operating Modes Selection	■
Flow and pressure adjustment of hydraulics lines controlled from the cab	■
Boom & arm cylinder safety valves	■
Mineral hydraulic oil	■
Safety valves (boom & arm)	■
PE3C - 2 way aux. Hydr. line for opening / closing tool (pedal ctrl)	●
PERO - low flow aux. hydr. line for rotating or tilting tool (joystick ctrl)	●

Undercarriage

Heavy-duty material handling frame	■
HD axle (3m width)	■
Front axle oscillating hydraulically ($\pm 8^\circ$)	■
Front and rear outriggers	■
12.00-20 SOLID tires	●

Safety

Rear and side camera	■
Side mirrors	■
Guard rail	■
Overload warning device	■
Light Pack : 6x LED Lights - 2 on Boom 4 on top of the Cab + rotation beacon.	■
FOGS windscreen and roof	●
Fire extinguisher	●

Cab and Interior

2.7m Elevating Cab with emergency lowering valves	■
7 inch color LCD gauge panel	■
High performance air conditioning with electronic climate control of the temperature	■
RADIO+MP3(STEREO) with Bluetooth Streaming and Handsfree Call	■
USB port	■
Sliding proportional control on joystick of auxiliary hydraulic lines	■
Cab pack : sun visor, roof window and rain shield	■
Fully adjustable air suspension seat with heater	■
Parallel Wipers	■

Other

8.7 m Material handling straight (mono) boom	■
6.9 m Material handling gooseneck arm	■
Double tyres with spacer rings 12.00-20	■
Fuel filling pump	■
Counterweight 7.3 tons	■
1 year warranty / 2.000 hours (whatever occurs first)	■
Automatic greasing system	■
Telematics system Track unit (hardware installation only, data plan purchase needed)	●
Bucket cylinder (straight arms w/o bucket cylinder in standard)	●

Certain specification(s) are based on engineering calculations and are not actual measurements. Specification(s) are provided for comparison purposes only and are subject to change without notice. Specification(s) for your individual DEVELON equipment will vary based on normal variations in design, manufacturing, operating conditions, and other factors. Pictures of DEVELON units may show other than standard equipment.

Powered by Innovation

**DISCOVER MORE:
DX350WMH-7**

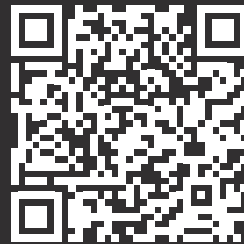

HD Construction Equipment Develon Europe s.r.o.
IBC - Pobrezni 620/3,
18600 Praha 8 - Karlín, Czechia

©2025 HD Construction Equipment Develon Europe s.r.o.
All rights reserved.
SPWMH00005 (08/2025)

DEVELON